

LOW NOISE AMPLIFIER 1GHZ~3GHZ

UCL-LNA0103-35-18-S SPECIFICATIONS

REVISION HISTORY			
REV	DESCRIPTION	DATE	APPROVED
A	PRODUCTION		

Parameter	Min.	Typ.	Max.	Units
Frequency Range	1		3	GHz
Gain	30	35		dB
Gain Flatness		±1.0	±2.0	dB
Gain Variation Over Temperature(-45 ~ +85)		±1.0		dB
Noise Figure		0.5	0.8	dB
Input VSWR		1.4	3.0	: 1
Output VSWR		1.8	2.0	: 1
Output 1dB Compression Point (P1dB)	15	18		dBm
Saturated Output Power (Psat)		21		dBm
Output Third Order Intercept (IP3)		28		dBm
Supply Current (Vcc=+15V)		150	200	mA
Isolation S12		-65		dB

Weight	1.06 ounces	Impedance	50ohms
Input / Output Connectors	SMA-Female	Material	Aluminum
Finish	Standard: Gold 40 micron; Nickel 220 micron thickness	Package Sealing	Epoxy Sealed (Standard)
	Option: Gold 80 micron; Nickel 180 micron thickness		Hermetically Sealed (Option with extra charge)

Absolute Maximum Ratings

Operating Voltage	+12V~+16V
RF Input Power	-10dBm

Biasing Up Procedure

Step 1	Connect Ground Pin
Step 2	Connect input and output
Step 3	Connect +15V biasing

Power OFF Procedure

Step 1	Turn off +15V biasing
Step 2	Remove RF connection
Step 3	Remove Ground.

Environmental Specifications

Operational Temperature	-45°C~+85°C
Storage Temperature	-55°C~+125°C
Altitude	30,000 ft. (Epoxy Sealed Controlled environment)
	60,000 ft. 1.0psi min (Hermetically Sealed Un-controlled environment) (Optional)
Vibration	25g RMS (15 degrees 2KHz) endurance, 1 hour per axis
Humidity	100% RH at 35c, 95%RH at 40c
Shock	20G for 11msec half sine wave, 3 axis both directions

Outline Drawing:

All Dimensions in mm [inches]

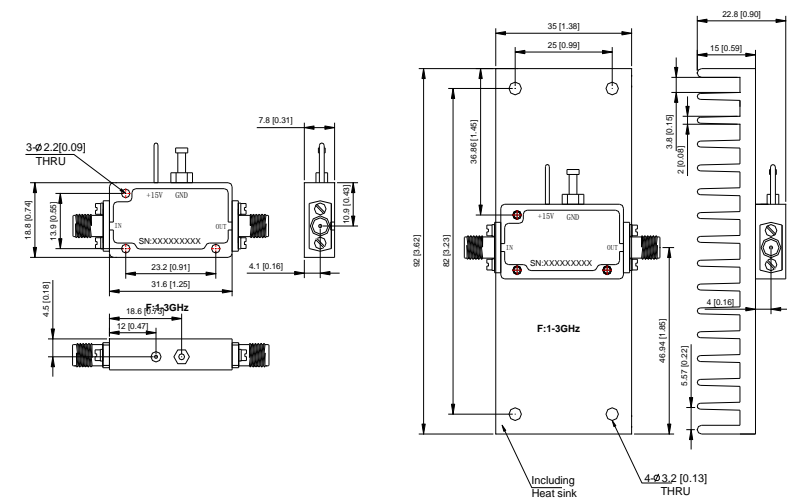

Heat Sink required during operation [Sold Separately]



Universal Cooperate Ltd.

Web:www.ucl-microwave.com

46 Langham Rd
Edgware,
HA8 9EL The UK

TITLE			
LOW NOISE AMPLIFIER 1GHZ~3GHZ			
SIZE	CAGE CODE	MODEL	REV
A		UCL-LNA0103-35-18-S	A
SCALE 1:1		DOC FAMILY	

Gain @+25°C

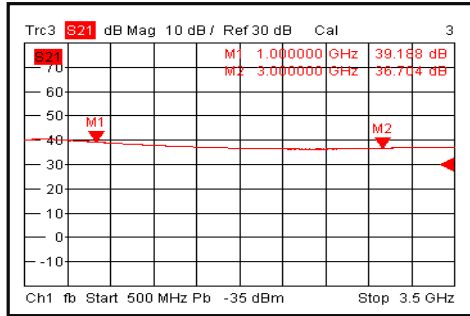

Input VSWR @+25°C

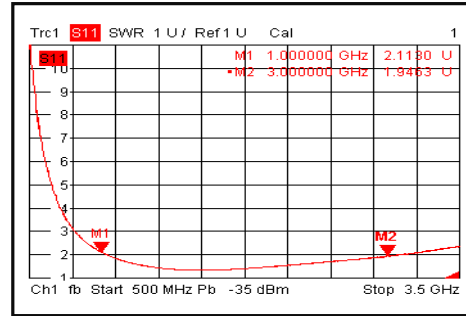

Output VSWR @+25°C

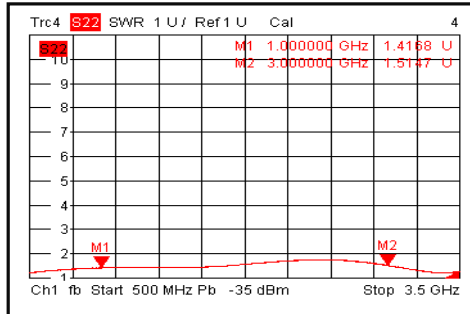

Isolation @+25°C

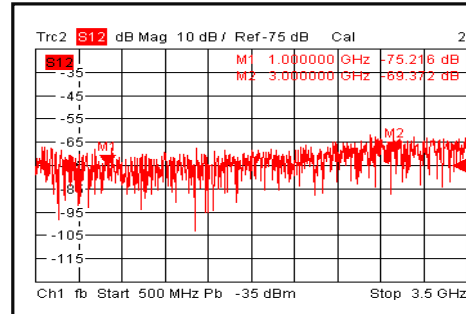

Gain @-45°C

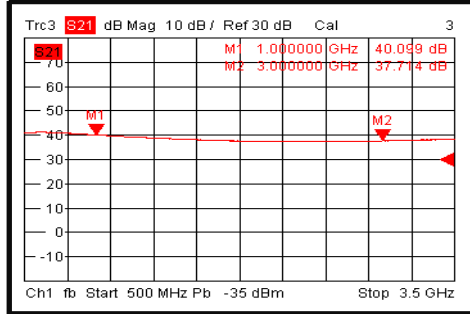

Input VSWR @-45°C

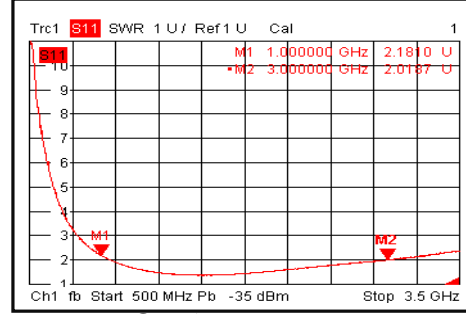

Output VSWR @-45°C

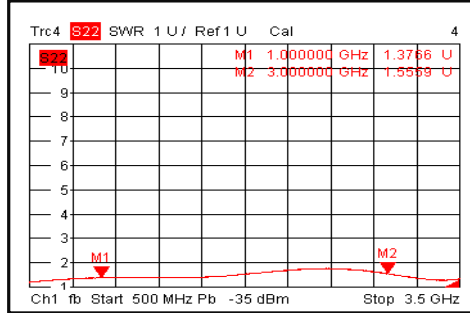

Isolation @-45°C

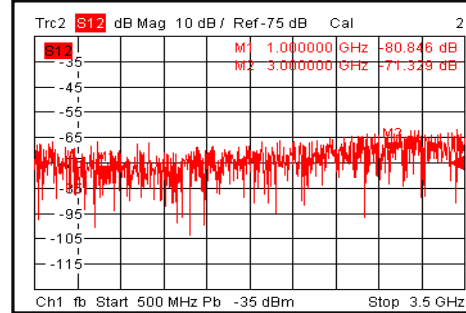

Gain @+85°C

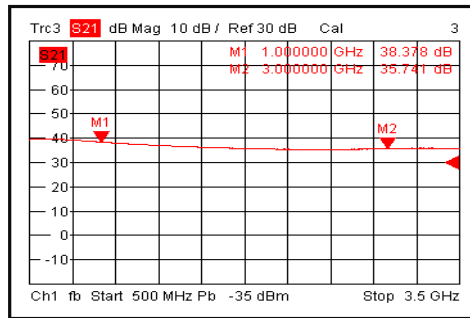

Input VSWR @+85°C

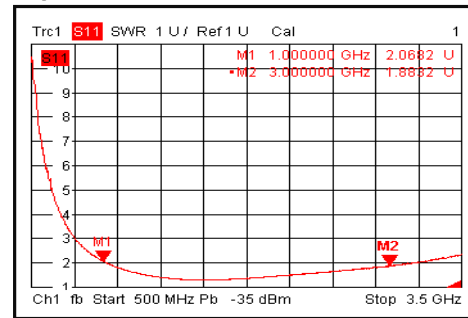

Output VSWR @+85°C

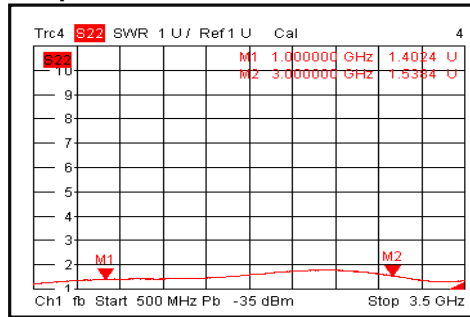

Isolation @+85°C

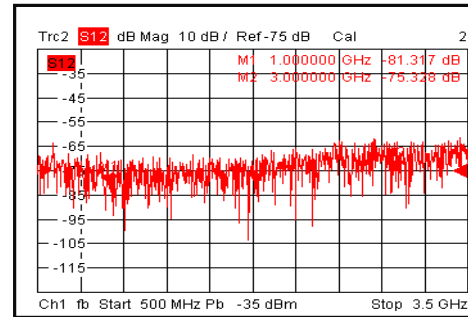

Gain vs. Output Power

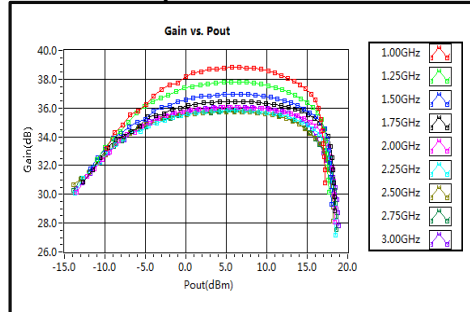

P1dB vs. Frequency

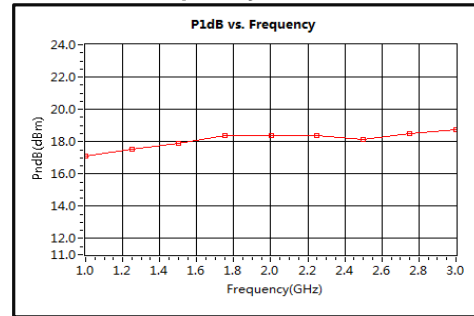

Output Third Order Intercept (IP3)

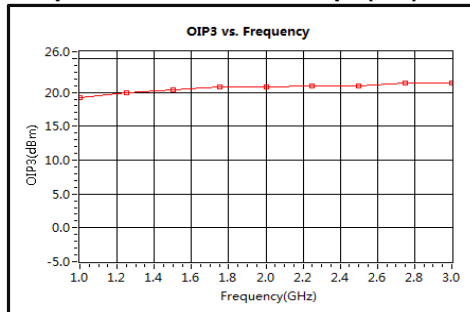

Noise Figure

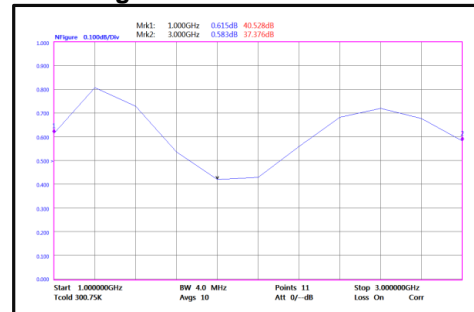

2nd Harmonic Wave Output Power

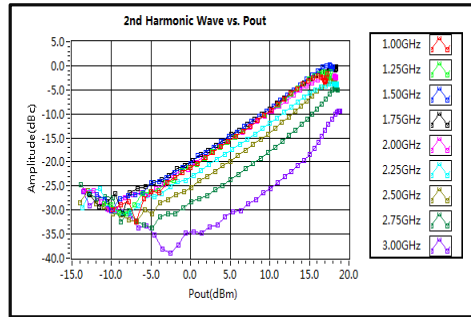

3rd Harmonic Wave Output Power

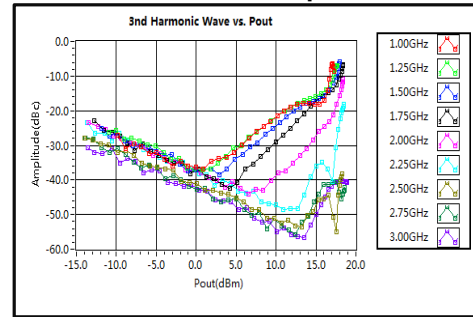

4th Harmonic Wave Output Power

