

# SMA-K BANDPASS FILTER 8200-12300MHZ

UCL-BPF8012-S

## ELECTRICAL SPECIFICATIONS

FREQUENCY RANGE :8200-12300MHZ  
 INSERTION LOSS: 2.0DB MAX  
 REJECTION:50DB @ 7200MHZ & 13300MHZ  
 VSWR:1.8 MAX  
 CONNECTORS: SMA-K  
 OPERATION TEMPERATURE: -40 ~ +70°C

REVISION HISTORY			
REV	DESCRIPTION	DATE	APPROVED
A	PRODUCTION RELEASE	6/10/2005	YF

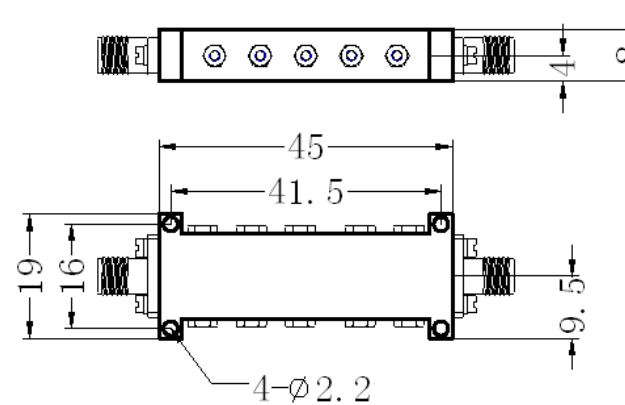

 <b>Universal Cooperate Ltd.</b> Web:www.ucl-microwave.com		46 Langham Rd Edgware, HA8 9EL The UK	
TITLE			
<h2>SMA-K BANDPASS FILTER 8200-12300MHZ</h2>			
SIZE	CAGE CODE	MODEL	REV
A		UCL-BPF8012-S	A
SCALE 1:1	DOC FAMILY BPF	SHEET 1 OF 1	